

CONCRETE PREFAB LIFT STATION

CONTROL PANEL

SWINGPANEL VIEW

BACKPLATE VIEW

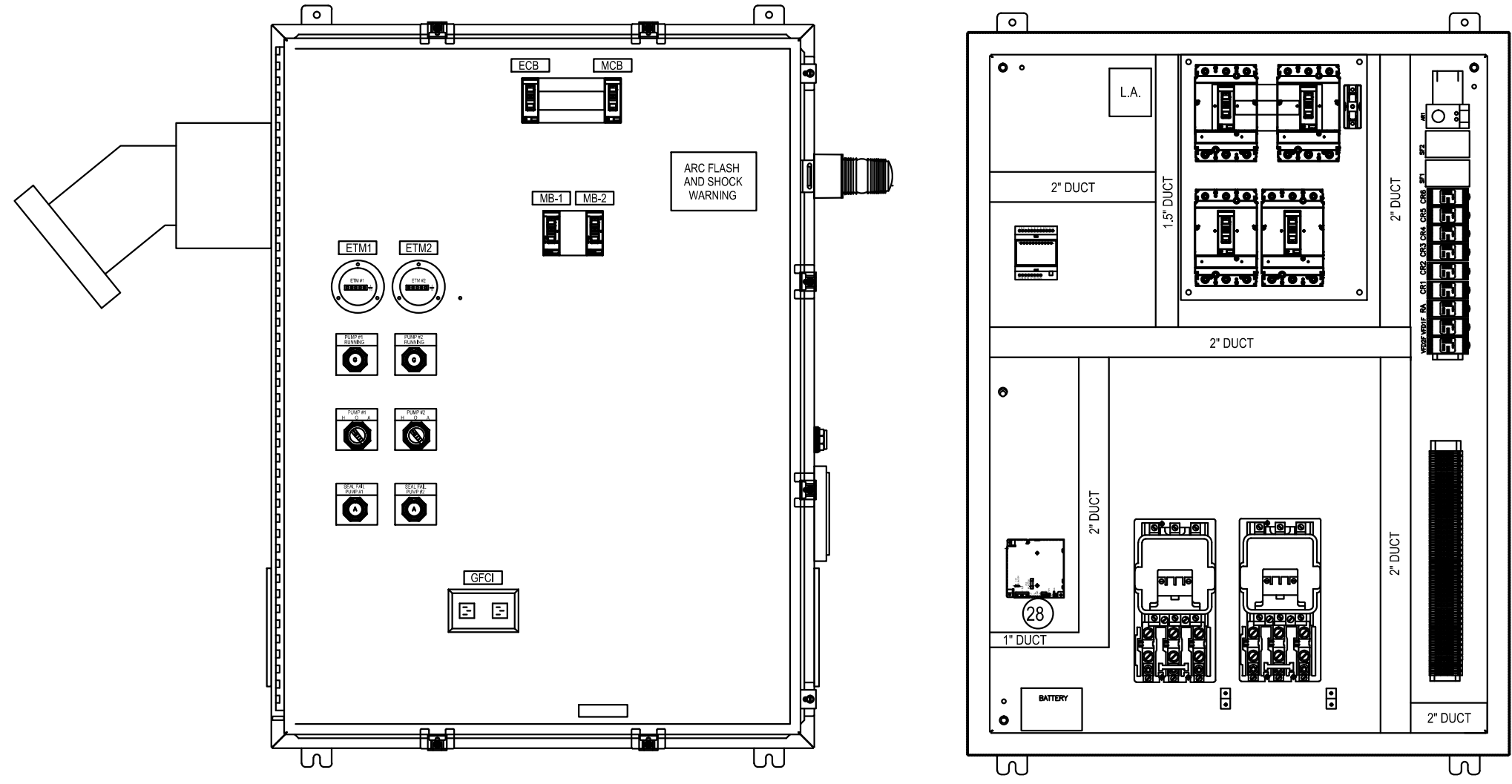

BASIN LAYOUT

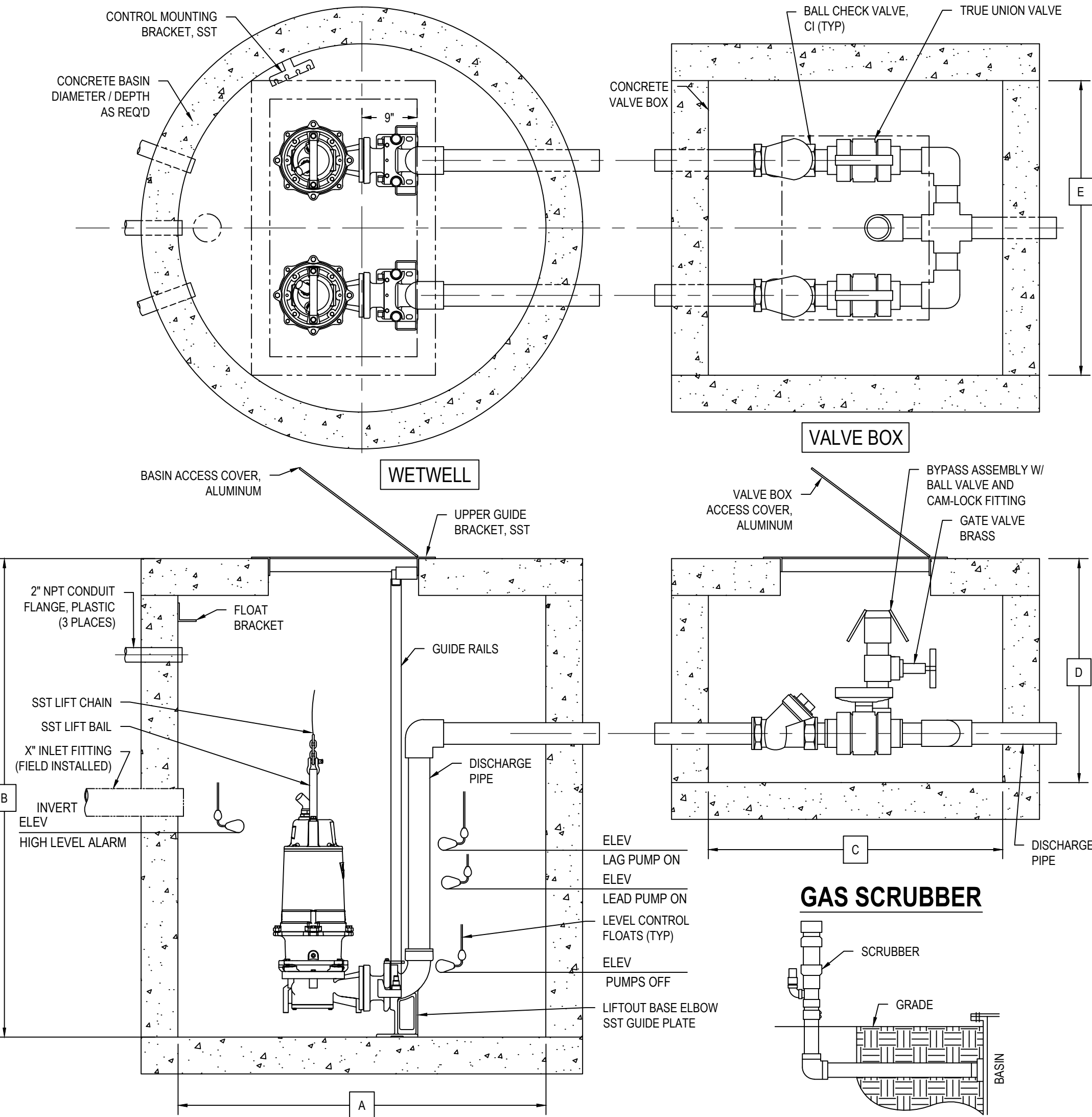

PANEL SCHEMATIC

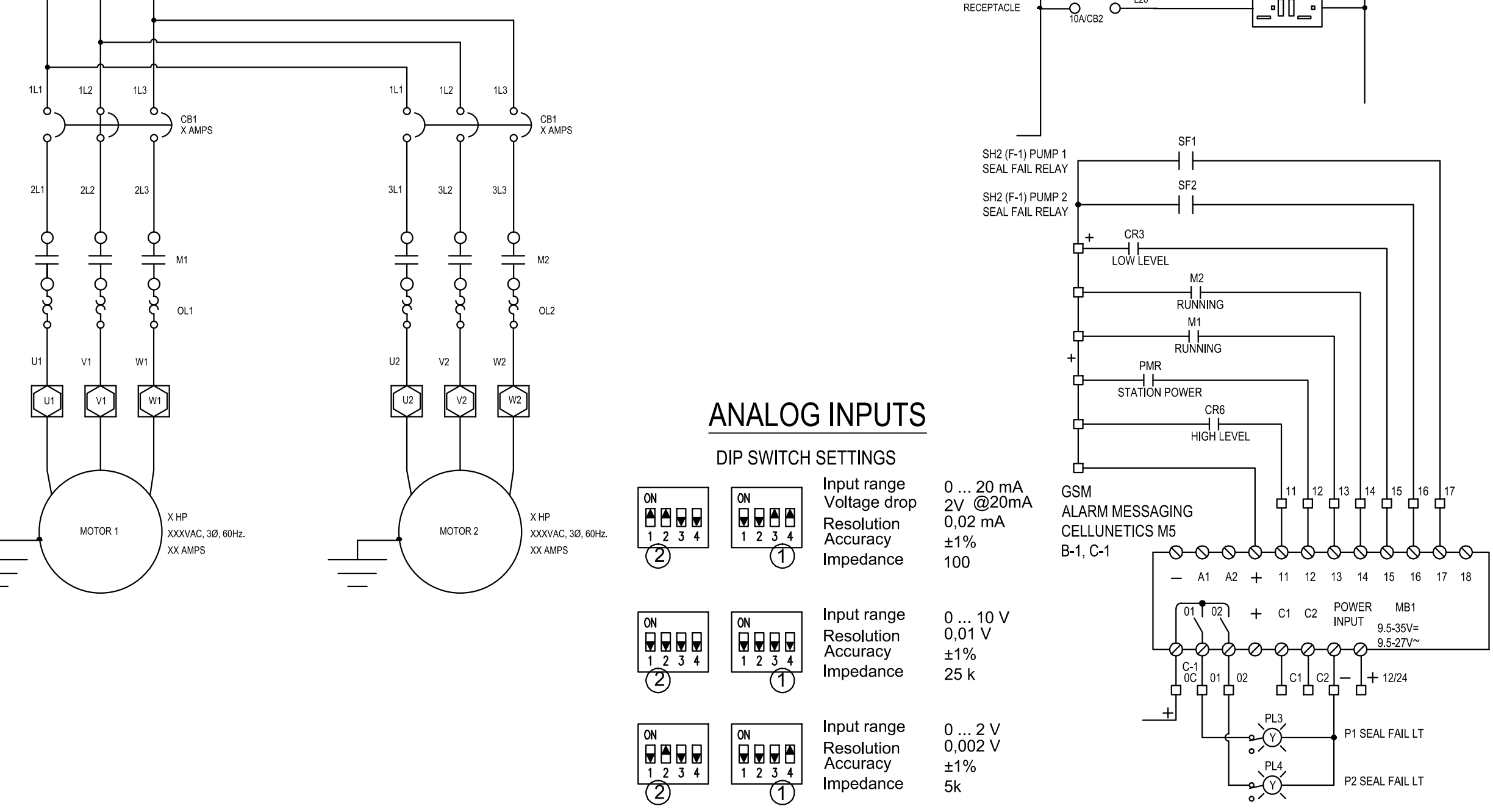
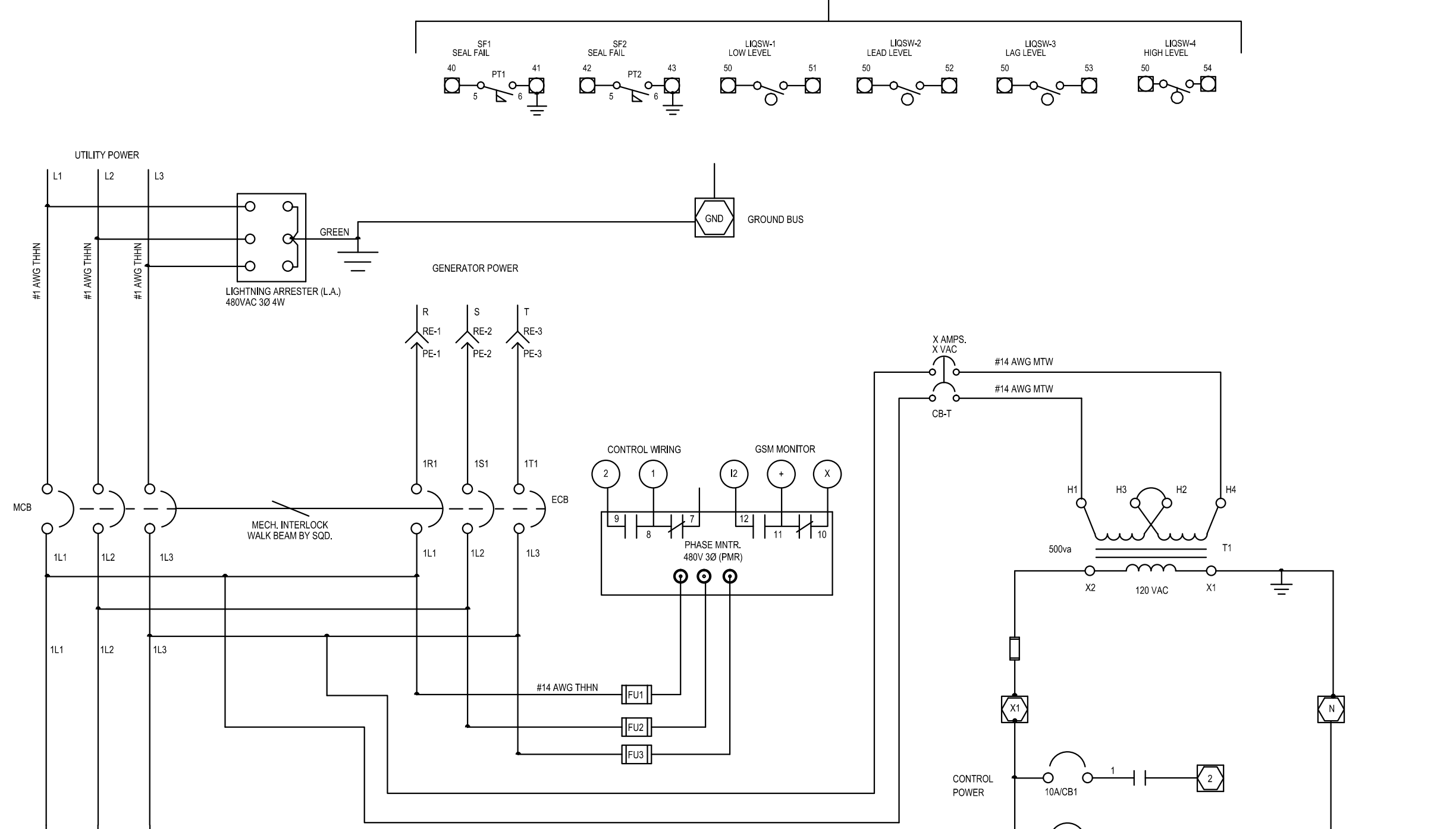
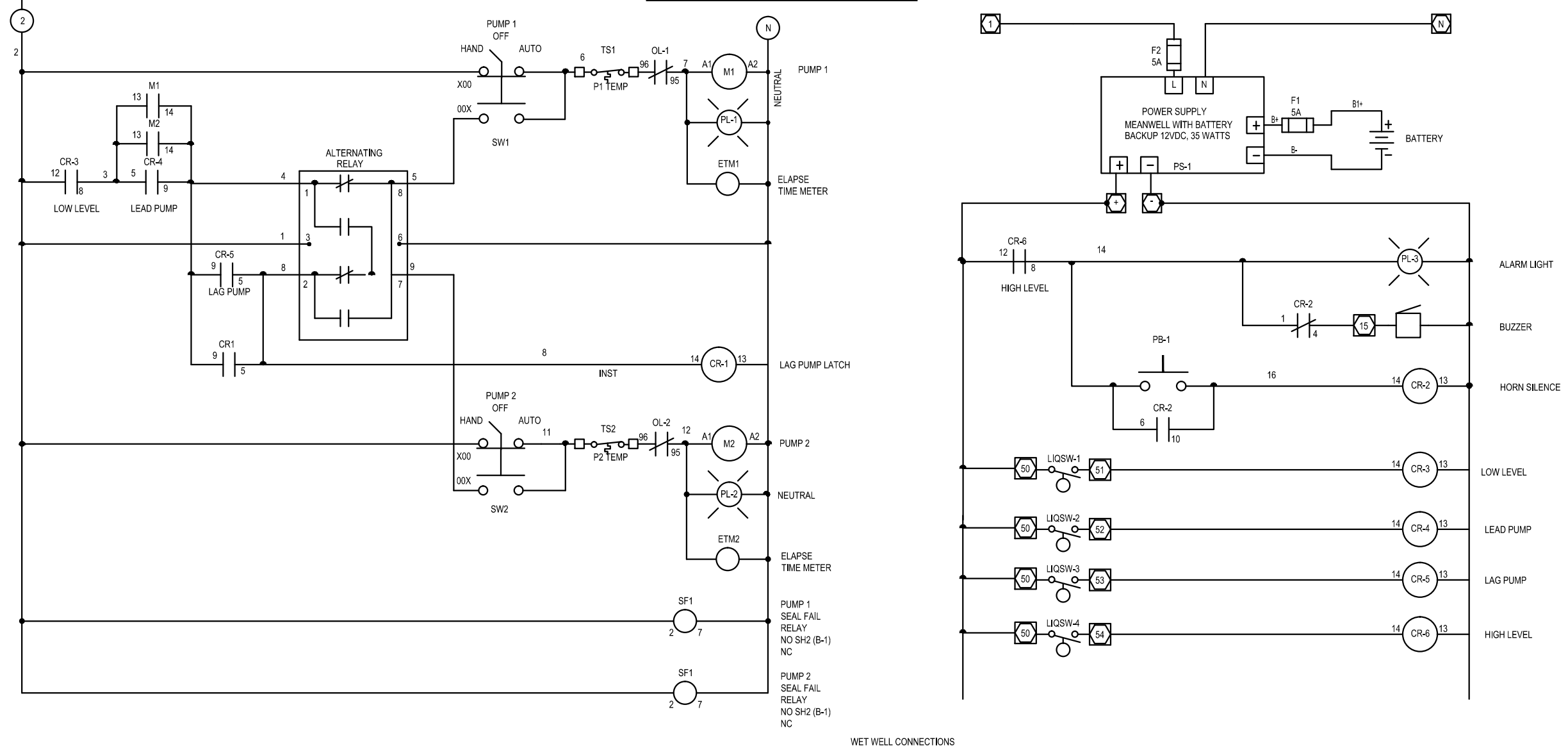

LIFT STATION DATA TABLE

WWS PREFAB LIFT STATION DATA	
DESIGN FLOW	BASIN INSIDE DIAMETER (A)
DESIGN TDH	BASIN DEPTH (B)
SHUTOFF HEAD	VALVE BOX DIMENSIONS (C, D, E)
MOTOR SPEED	HATCH COVER RATING
MOTOR HP	WET WELL HATCH COVER DIMS
PUMP MODEL	VALVE BOX HATCH COVER DIMS
PUMP TYPE	DISCHARGE PIPE TYPE
SOLIDS SIZE	DISCHARGE PIPE SIZE
DISCHARGE SIZE	HIGH LEVEL ALARM FLOAT
VOLTAGE	LAG PUMP ON FLOAT
PHASE	LEAD PUMP ON FLOAT
FULL LOAD AMPS	PUMPS OFF FLOAT
ZINC ANODE MODEL	WWS-ZC4 5-790F
	WWS-GS-PVS-2002

LIFT STATION SPECS

WWS PREFAB LIFT STATION IS IN ACCORDANCE WITH THE FOLLOWING STANDARDS:

DEP FLORIDA ADMINISTRATIVE CODE (FAC) RULE 62.604.400. COLLECTION SYSTEMS AND TRANSMISSION FACILITIES.

RECOMMENDED STANDARDS FOR WASTEWATER FACILITIES (RSWF), 2014 EDITION. GREAT LAKES-UPPER MISSISSIPPI RIVER (10 STATE STANDARDS), CHAPTER 40. SUBCHAPTER 42.

NATIONAL ELECTRIC CODE (NEC) CLASS 1, DIVISION 1, GROUP D HAZARDOUS LOCATIONS

UNDERWRITER'S LABORATORIES (UL) 508A FOR INDUSTRIAL CONTROL PANELS FOR ORDINARY LOCATIONS AND 698A FOR HAZARDOUS LOCATIONS WITH INTRINSICALLY SAFE CIRCUIT EXTENSIONS.

SPECIFIC CONSTRUCTION STANDARDS:

THE EQUIPMENT WILL BE COVERED IN 100% NON-PRORATED WARRANTY FOR (3) THREE YEARS.

PUMPS SHALL BE EXPLOSION-PROOF, CLASS 1, DIVISION 1, GROUPS C & D CONSTRUCTION.

CONTROL PANEL SHALL HAVE UL 508A CERTIFICATION.

NON-CLOG SUBMERSIBLE PUMPS WILL HAVE A MINIMUM OF 3" SOLIDS PASSAGE.

PUMP MOTORS SERVICE FACTOR WILL BE NO LESS THAN 1.20.

PUMPS WILL FEATURE A TWO-BEARING HIGH LOAD ANGULAR CONTACT 100,000 HOUR B-10 LIFE.

PUMPS WILL HAVE SEVERE DUTY DUAL SILICON-CARBIDE MECHANICAL SEALS.

PUMPS WILL CONTAIN A SEAL LEAK PROBE SIGNAL ALARM FOR MOISTURE DETECTION.

GAS SCRUBBER WILL BE MODEL WWS-GS-PVS-2002 CONSISTING OF DRY-SCRUBBING MEDIA IN A REFILLABLE HOUSING WITH VENT REPLACEMENT DFU VACUUM BREAK VALVE. IT SHALL CONTAIN UL-900 MEDIA OF ESD MIXED WITH: (1) ODOCARB ULTRA, (2) PURAFILL ODOROXIDANT SP, (3) PURAFILL ODORKOL. ONLY UL-900 CERTIFIED MEDIA WILL BE ACCEPTED. SCRUBBER TO OPERATE AT 99.5% GAS REMOVAL EFFICIENCY. AIRFLOW CAPACITY SHALL RANGE FROM 0 CFM TO 30 CFM OR PASSIVE. MEDIA MANUFACTURER TO BE CERTIFIED TO ISO-9001:2000 STANDARDS. ISO CERTIFICATE MUST BE SUPPLIED WITH SUBMITTALS.

THE CONTROL PANEL WILL BE EQUIPPED WITH A COMPACT ALERTING & CONTROL DEVICE MODEL WWS-MBI-2500 WHICH WILL MONITOR AND CONTROL THE LIFT STATION PUMP UNITS FROM A MOBILE PHONE OR VIA THE INTERNET. FAULTS OR ALARMS WILL SEND A SMS OR EMAIL MESSAGE TO ONE OR MORE RECIPIENTS. THE DEVICE WILL PROVIDE DETAILED REPORTS ON ITS COMPLETE STATUS AND SEND PERIODIC MESSAGES. OUTPUTS WILL BE CONTROLLED BY AUTHORIZED USERS VIA SMS, TWEET, FREE PHONE RINGS AND PHONE KEYBOARD. NO EQUIVALENTS WILL BE ACCEPTED.

ZINC ANODE WILL BE MODEL WWS-ZC4-5-790F CONSISTING OF A 1"X2"X9" MINIMUM 99.7% PURE ZINC CATHODIC PROTECTOR AS PER MIL SPEC A-18001K MILITARY SPECIFICATION; ANODES, SACRIFICIAL ZINC ALLOY. UNIT TO BE INSTALLED BELOW PUMP MINIMUM SUBMERGENCE LEVEL. NO SUBSTITUTIONS WILL BE ACCEPTED.

SYMBOL LEGEND

- 35 INDICATES REMOTE TERMINAL OR REMOTE WIRE NUMBER. LOCATED IN THE FIELD.
- 35 INDICATES LOCAL TERMINAL OR LOCAL WIRE NUMBER. LOCATED IN THE MAIN CONTROL PANEL.
- 35 INDICATES LOCAL WIRE NUMBER AND DOESN NOT GO TO ANY TERMINAL POINT IN THE MAIN PANEL.
- R032 INDICATES DEVICE TERMINAL OR NUMBER ON AN ELECTRICAL OR ELECTRONIC DEVICE. LOCAL OR REMOTE.
- MASTER ACCESS INDICATES A REMOTE STATION OF AN OPERATOR OR STATION NOT MOUNTED ON THE MAIN PANEL.
- ELECTRICALLY CONNECTED
- NOT ELECTRICALLY CONNECTED
- /43 INDICATES XREF. OF CONTRACT, 4 MEANS THE PAGE NO. & 3 MEANS THE GRID NO. IN PAGE 4
- ∨ INDICATES A RECEPTACLE/PLUG FOR THE HOOK-UP OF THE GENERATOR FROM THE OUTSIDE.

CONTROL PANEL NOTES:

CONTROL PANEL SHALL BE PROVIDED WITH A BATTERY BACK-UP SYSTEM WHICH SHALL DISPLAY AN ALARM CONDITION WHENEVER THE PUMP STATION SUFFERS A HIGH WETWELL LEVEL OR LOSS OF STATION POWER. THE STATION ALARM SHALL BE A MINIMUM 300 LUM RED LIGHT, FLASHING TWO SECONDS ON, FOUR SECONDS OFF. THE STATION AUDIO ALARM SHALL PROVIDE A MINIMUM LEVEL OF 85 db AT 10 FEET, WITH SILENCING SWITCH. THE SYSTEM BATTERY SHALL BE RECHARGEABLE AND SUFFICIENT TO OPERATE BOTH ALARMS FOR A MINIMUM OF 12 HOURS. A BATTERY CHARGER SHALL BE PROVIDED AND BE ABLE TO FULLY RECHARGE A DISCHARGED BATTERY WITHIN 48 HOURS UPON RETURN OF UTILITY POWER. THE BATTERY SHALL BE REPLACED ACCORDING TO THE RECOMMENDATIONS OF THE ALARM MANUFACTURER AND SHALL BE INDELIBLY MARKED WITH THE DATE OF INSTALLATION.

UNITS	SCALE	STANDARD	D	N.T.S.	DATE	REV	COMMENTS
					12-06-16		

WASTEWATER SOLUTIONS LLC
 CONTACT: ARTURO GARCIA
 PHONE: (954) 483-9269
 EMAIL: ARTURO@WWS-LLC.COM
 102 NE 2ND STREET, SUITE 510
 BOCA RATON, FLORIDA 33432

CONCRETE LIFT STATION DETAILS

NAME PREPARED FOR COMPANY ADDRESS

SHEET NUMBER XX-XX