

BASIN DETAILS

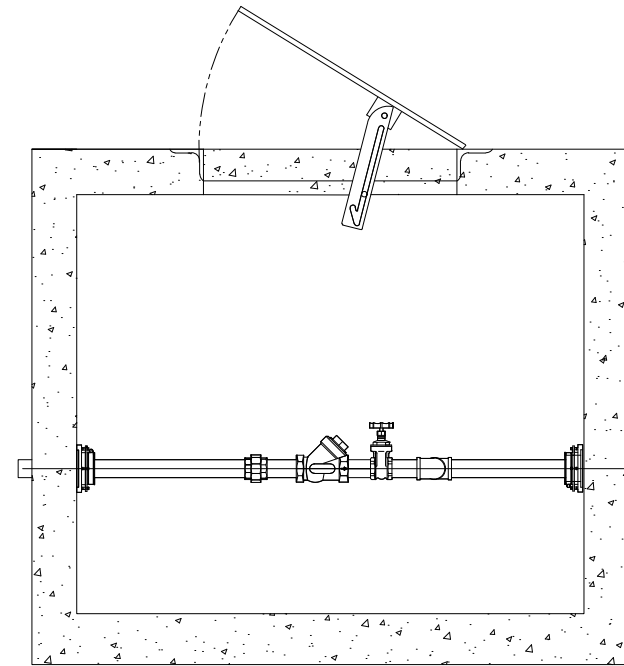

CONTROL PANEL

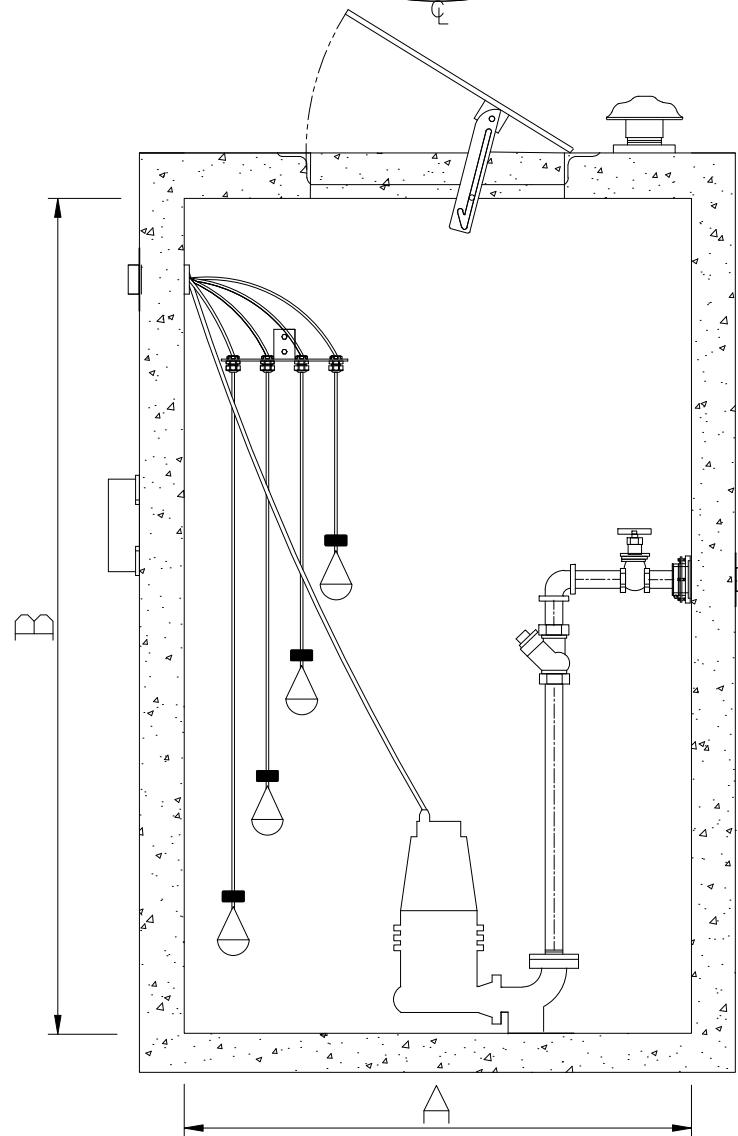
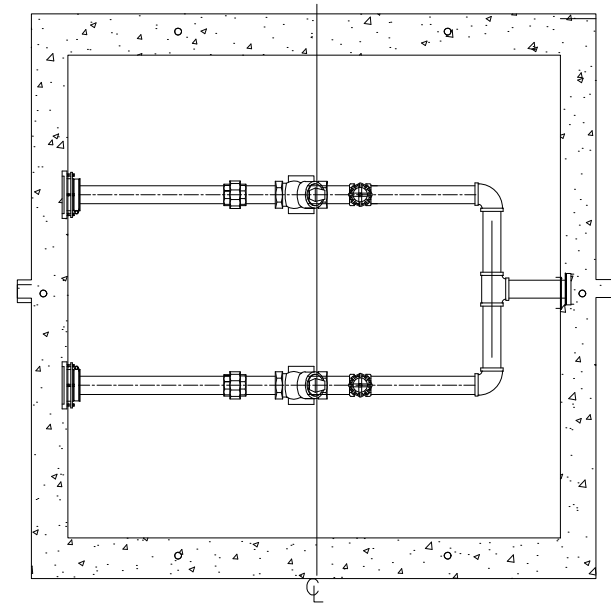
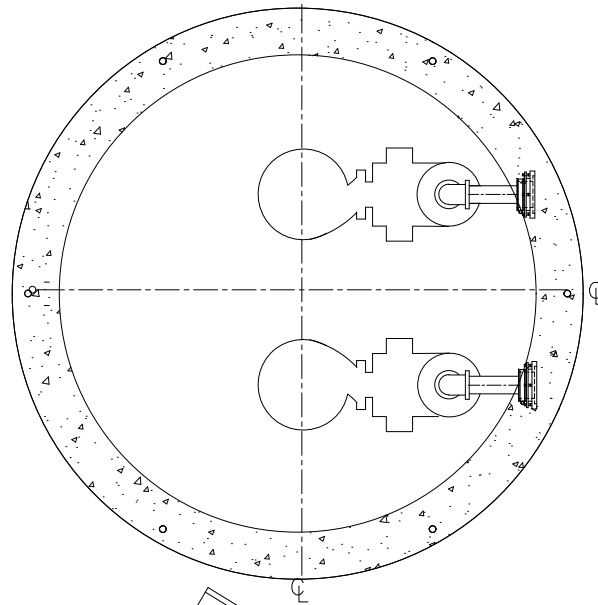
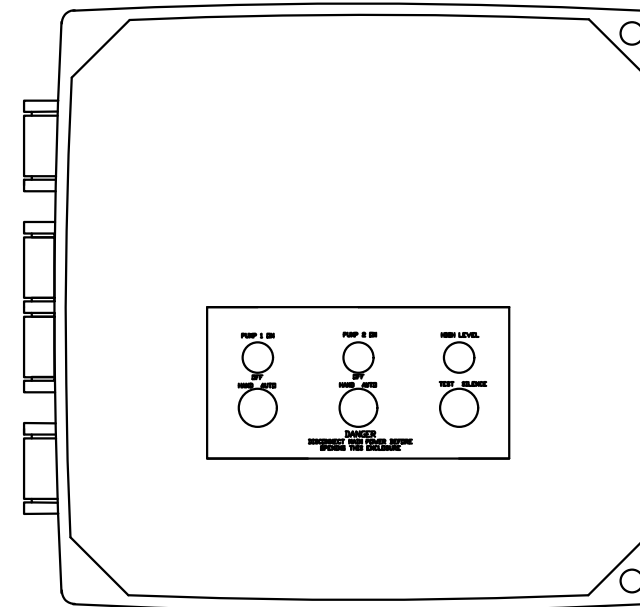

- Standard components:
- 1- 16 x 14 x 7 NEMA 4X polycarbonate enclosure.
 - 2- IEC motor contactor.
 - 3- MCC B for shorcut.
 - 4- Alternator.
 - 5- Green Pump run indicator lights.
 - 6- Alarm/Control CB.
 - 7- Float switch terminal block angled for ease of field installation.
 - 8- Input power terminal block angled for ease of field installation.
 - 9- Ground lugs.
 - 10- HOA(Hand/Off/Auto) switches.

- Standard Alarm Package:
- 11- High alarm relay for dry contacts.
 - 12- Indicator light for visual check.
 - 13- Sonalert audible alarm.
 - 14- Exterior alarm test with silence.
 - 15- Horn silence relay.

GENERAL NOTES

BASIN DIAMETER (A)	
BASIN DEPTH (B)	
PHASE	
VOLTAGE	
PUMP MODEL	
FLOW (GPM)	
TDH (FEET)	
HP	
RPM	
DISCHARGE	
VALVEBOX DIMS	36'' X 40'' X 40''

NOTES:

PLEASE CONTACT
WASTEWATER SOLUTIONS LLC
ARTURO GARCIA
(954)-483-9269
Email: Arturo@WWS-LLC.com

DUPLEX EJECTOR WITH VALVEBOX
HARD PIPED STATION
CONCRETE BASIN

Revision notes:

Rev:	Date:	Notes:
A	19/07/21	PROJECT

Drawn by:

C.Grajeda

Client:

Project:

WASTEWATER

Drawing Title:

DUPLEX EJECTOR WITH VALVEBOX HP

Date:

17/07/21

Scale @ A3:

XXXX

Revision:

A

