

## BASIN DETAILS

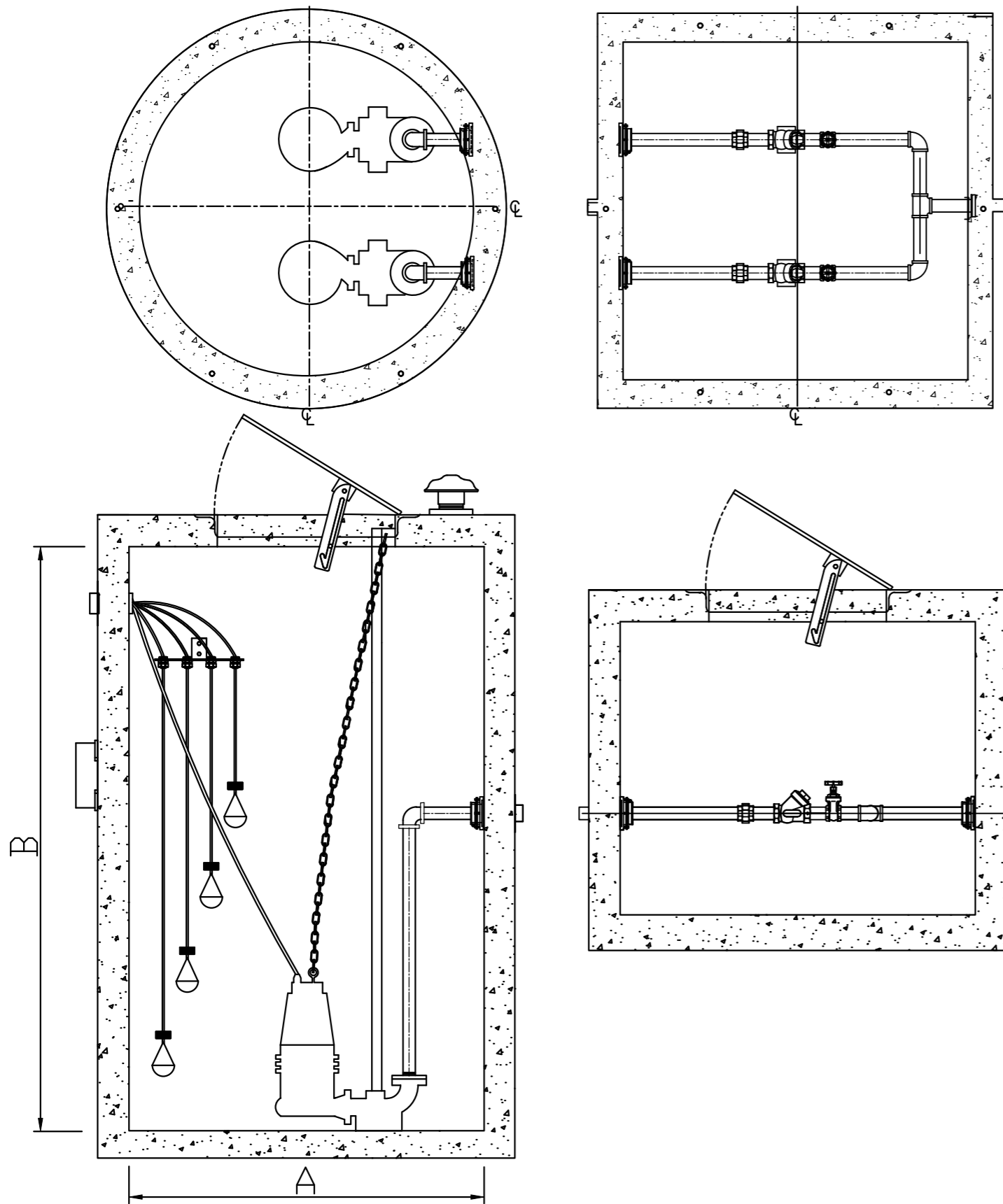

## CONTROL PANEL

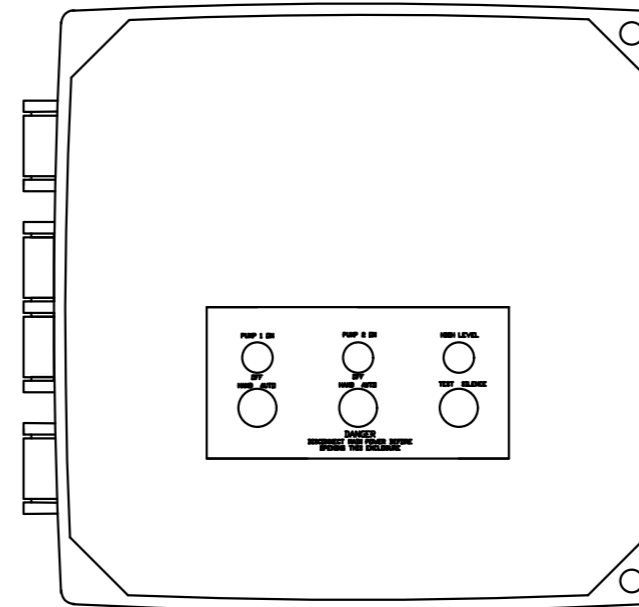

- Standard components:
- 1- 16 x 14 x 7 NEMA 4X polycarbonate enclosure.
  - 2- IEC motor contactor.
  - 3- MCC B for shorcut.
  - 4- Alternator.
  - 5- Green Pump run indicator lights.
  - 6- Alarm/Control CB.
  - 7- Float switch terminal block angled for ease of field installation.
  - 8- Input power terminal block angled for ease of field installation.
  - 9- Ground lugs.
  - 10- HOA(Hand/Off/Auto) switches.

- Standard Alarm Package:
- 11- High alarm relay for dry contacts.
  - 12- Indicator light for visual check.
  - 13- Sonalert audible alarm.
  - 14- Exterior alarm test with silence.
  - 15- Horn silence relay.

## GENERAL NOTES

BASIN DIAMETER (A)	
BASIN DEPTH (B)	
PHASE	
VOLTAGE	
PUMP MODEL	
FLOW (GPM)	
TDH (FEET)	
HP	
RPM	
DISCHARGE	
VALVEBOX DIMS	36" X 40" X 40"

### NOTES:

PLEASE CONTACT  
 WASTEWATER SOLUTIONS LLC  
 ARTURO GARCIA  
 (954)-483-9269  
 Email: Arturo@WWS-LLC.com

DUPLEX EJECTOR WITH VALVEBOX  
 CONCRETE BASIN

#### Revision notes:

Rev:	Date:	Notes:
A	10/14/19	PROJECT

#### Drawn by:

C.Grajeda

#### Client:

#### Project:

WASTEWATER

#### Drawing Title:

WWS DUPLEX EJECTOR WITH VALVEBOX

#### Date:

10/14/2019

#### Scale @ A3:

XXXX

#### Revision:

A

