

BASIN DETAILS

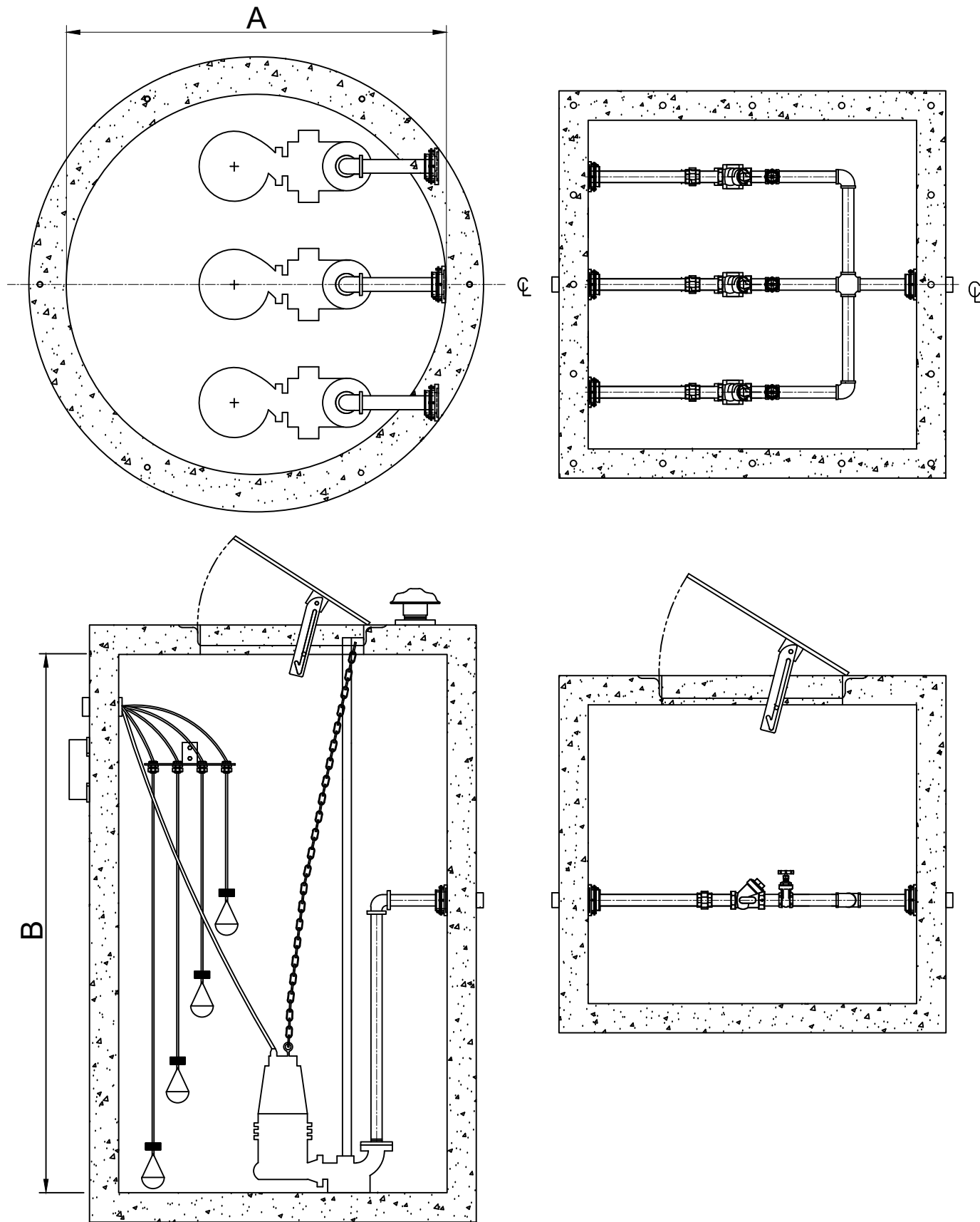

CONTROL PANEL

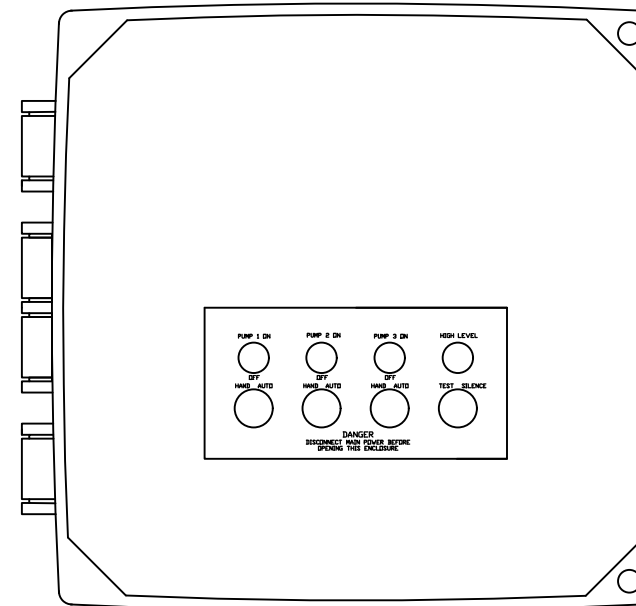

Standard components:

- 1- 16 x 14 x 7 NEMA 4X polycarbonate enclosure.
- 2- IEC motor contactor.
- 3- MCC B for short circuit.
- 4- Alternator.
- 5- Green Pump run indicator lights.
- 6- Alarm/Control CB.
- 7- Float switch terminal block angled for ease of field installation.
- 8- Input power terminal block angled for ease of field installation.
- 9- Ground lugs.
- 10- HOA(Hand/Off/Auto) switches.

Standard Alarm Package:

- 11- High alarm relay for dry contacts.
- 12- Indicator light for visual check.
- 13- Sonalert audible alarm.
- 14- Exterior alarm test with silence.
- 15- Horn silence relay.

GENERAL NOTES

BASIN LENGHT (A)	
BASIN DEPTH (B)	
PHASE	
VOLTAGE	
PUMP	
FLOW (GPM)	
TDH (FEET)	
HP	
RPM	
DISCHARGE	
VALVE BOX DIM.	

NOTES:

PLEASE CONTACT
WASTEWATER SOLUTIONS LLC
ARTURO GARCIA
 (954)-483-9269
 Email: Arturo@WWS-LLC.com

**TRIPLEX EJECTOR SYSTEM
 WITH VALVEBOX
 CONCRETE BASIN**

Revision notes:

Rev:	Date:	Notes:
A		PROYECT

Drawn by:
A. GONZALEZ

Client:

Project:

Drawing Title:
EJECTOR SYSTEM

Date:

Scale @ A3:

Revision:
A

